

## KBPC10/15/25/35/50AW -G SERIES

"-G" : RoHS Device

REVERSE VOLTAGE - 50 to 1000V

FORWARD CURRENT - 10/15/25/35/50A

### FEATURES

- Surge overload -240~500 Amperes peak
- Low forward voltage drop
- Mounting Position : Any
- Electrically isolated base -2000 Volts
- Materials used carries U/L recognition

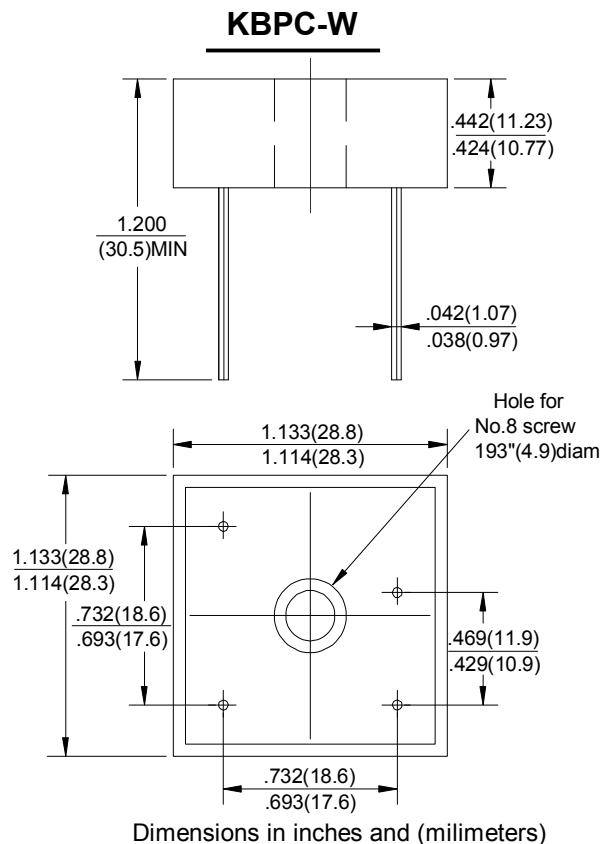

### MAXIMUM RATINGS AND ELECTRICAL CHARACTERISTICS

Rating at 25°C ambient temperature unless otherwise specified.

Resistive or inductive load 60Hz.

For capacitive load current by 20%

CHARACTERISTICS	SYMBOL	KBPC-W	KBPC-W	KBPC-W	KBPC-W	KBPC-W	KBPC-W	KBPC-W	KBPC-W	UNIT
		10005	1001	1002	1004	1006	1008	1010		
		15005	1501	1502	1504	1506	1508	1510		
		25005	2501	2502	2504	2506	2508	2510		
		35005	3501	3502	3504	3506	3508	3510		
		50005	5001	5002	5004	5006	5008	5010		
Maximum Recurrent Peak Reverse Voltage	V <sub>RRM</sub>	50	100	200	400	600	800	1000		V
Maximum RMS Bridge Input Voltage	V <sub>RMS</sub>	35	70	140	280	420	560	700		V
Maximum Average Forward Rectified Output Current @T <sub>c</sub> =55°C	I <sub(av)< sub=""></sub(av)<>	10	15	25	35	50				A
Peak Forward Surge Current 8.3ms Single Half Sine-Wave Super Imposed on Rated Load	I <sub>FSM</sub>	240	300	400	400	500				A
Maximum Forward Voltage Drop Per Element at 5.0/7.5/12.5/17.5/25.0A Peak	V <sub>F</sub>	1.1								V
Maximum Reverse Current at Rate DC Blocking Voltage Per Element @T <sub>J</sub> =25°C	I <sub>R</sub>	10								µA
Operating Temperature Range	T <sub>J</sub>	-55 to +125								°C
Storage Temperature Range	T <sub>STG</sub>	-55 to +150								°C

## RATINGS AND CHARACTERISTIC CURVES KBPC10/15/25/35/50AW -G SERIES

FIG.1-MAXIMUM FORWARD SURGE CURRENT

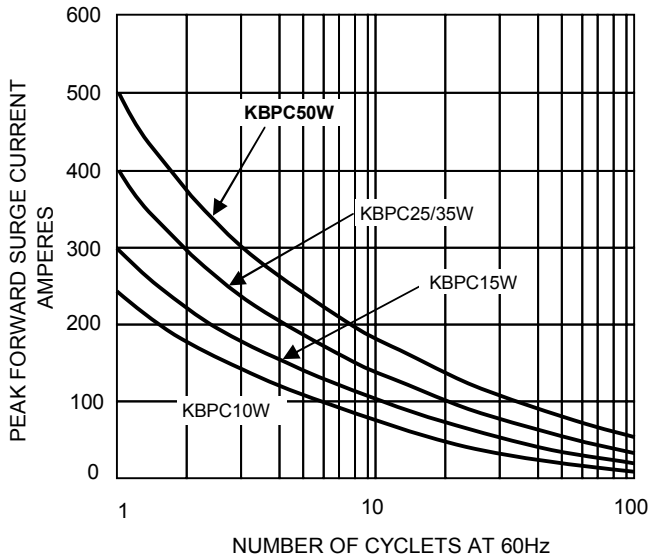

FIG.2- DERATING CURVE  
OUTPUT RECTIFIED CURRENT

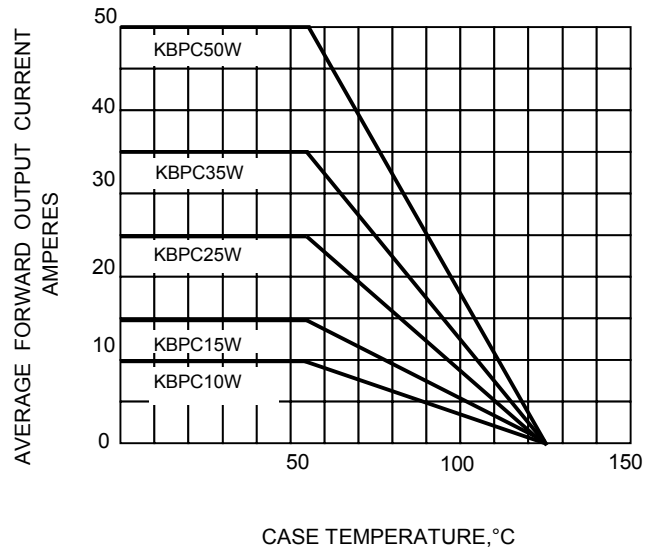

FIG.3-TYPICAL FORWARD CHARACTERISTICS

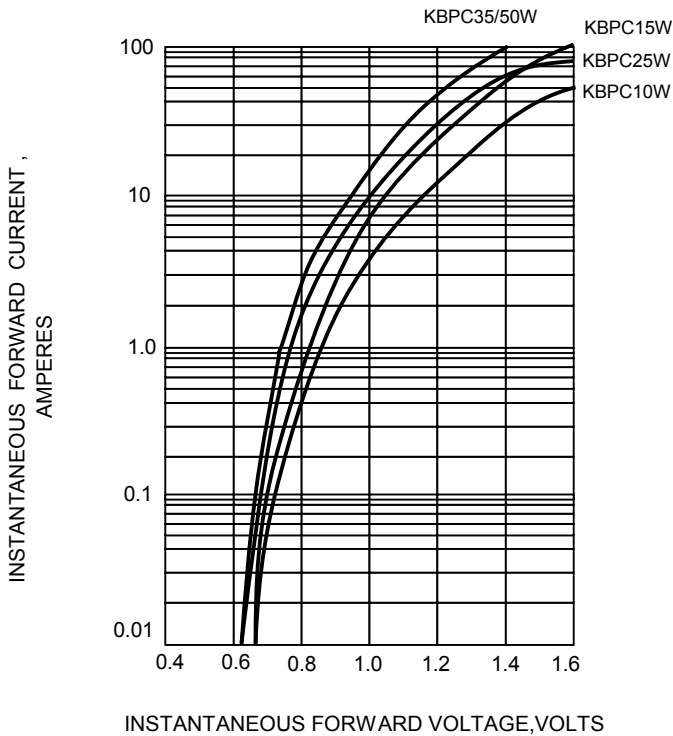

FIG.4-TYPICAL REVERSE CHARACTERISTICS

